

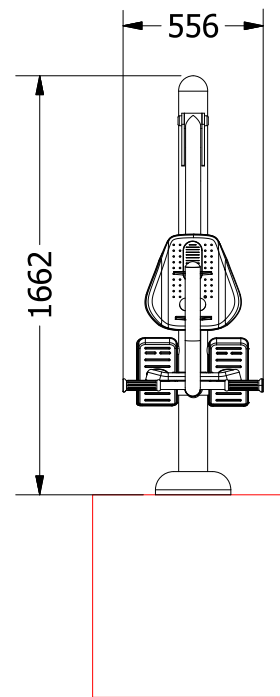

Prasa do nóg THJ-B13

SKALA
1:25

PN-EN 1176-1:2009, PN-EN 1176-7:2009
PN-EN ISO 20957-1:2014-02.

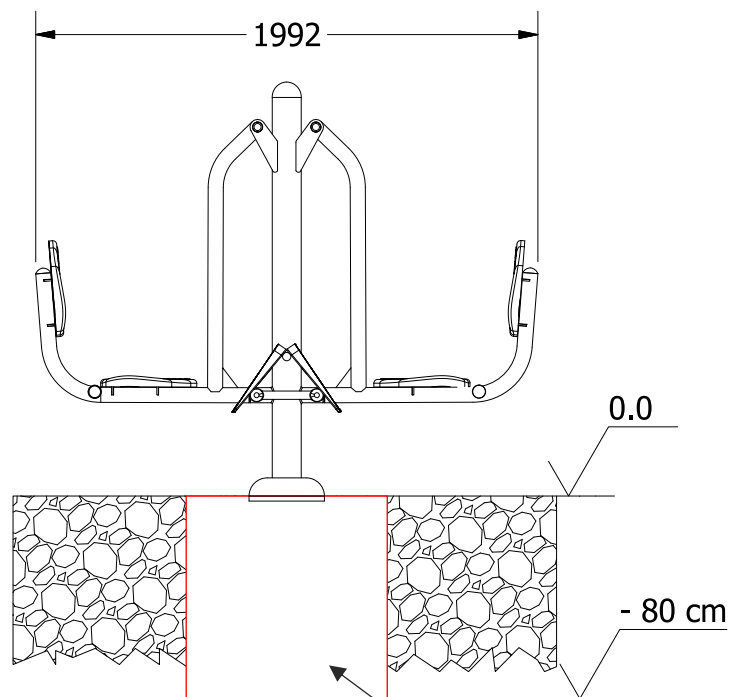

FUDAMENT 800x800x800

STREFA BEZPIECZEŃSTWA

5000

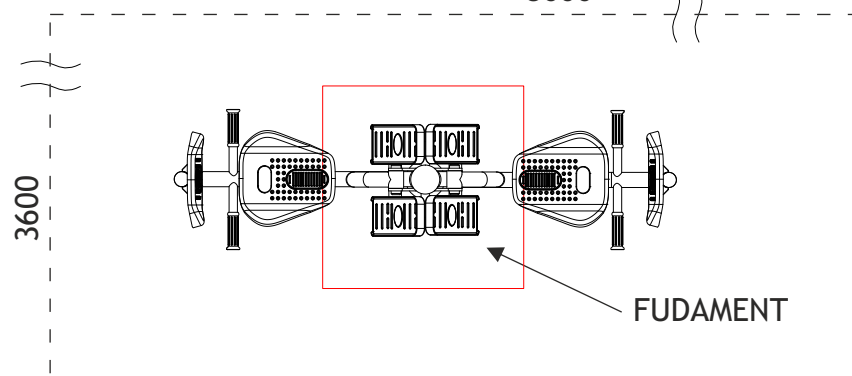

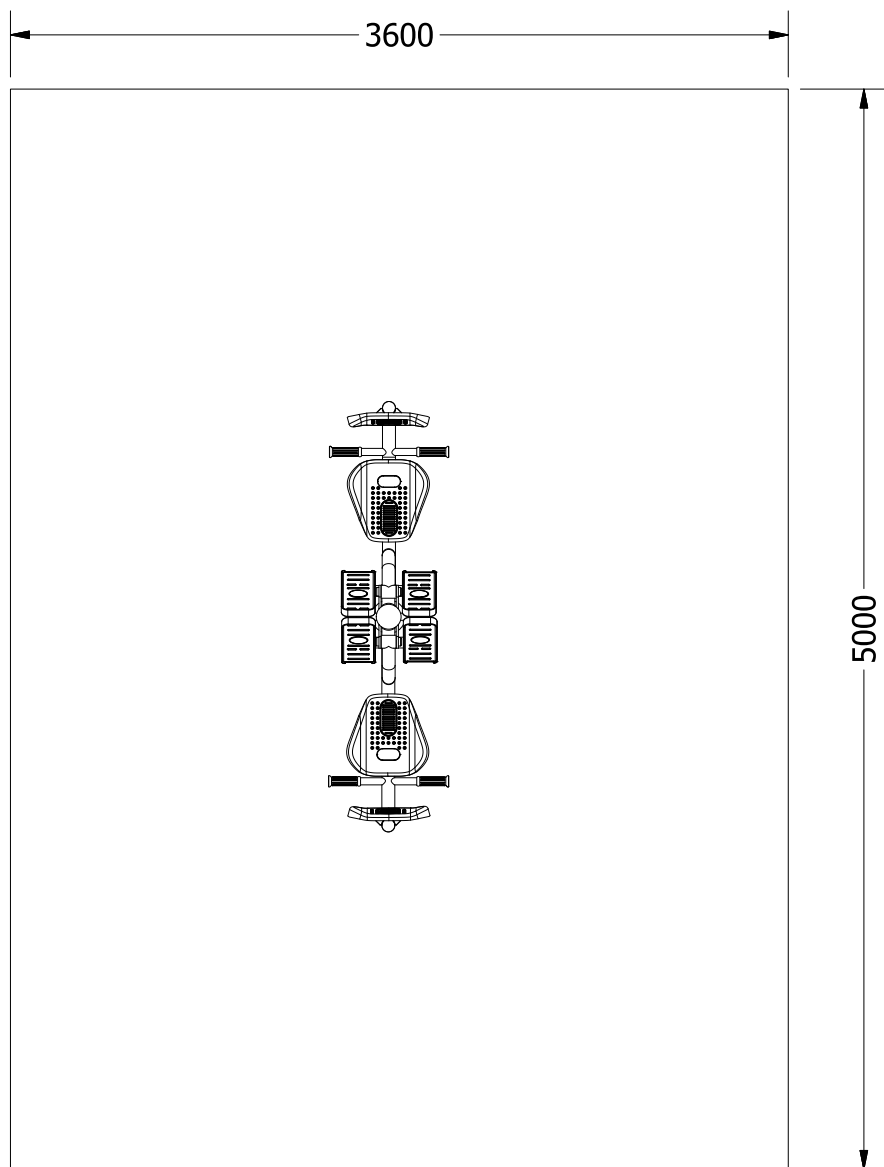

Max. waga ćwiczącego	120 kg
Funkcje	Poprawa muskulatury nóg, mięśnia czworogłowego uda, dwugłowego łydki oraz mięśni brzucha.
Stopień trudności	Średni
Certyfikaty	Urządzenie posiada certyfikat zgodności z polskimi normami: PN-EN 1176-1:2009, PN-EN 1176-7:2009, PN-EN ISO 20957-1:2014-02

Zaangażowane partie mięśni

