

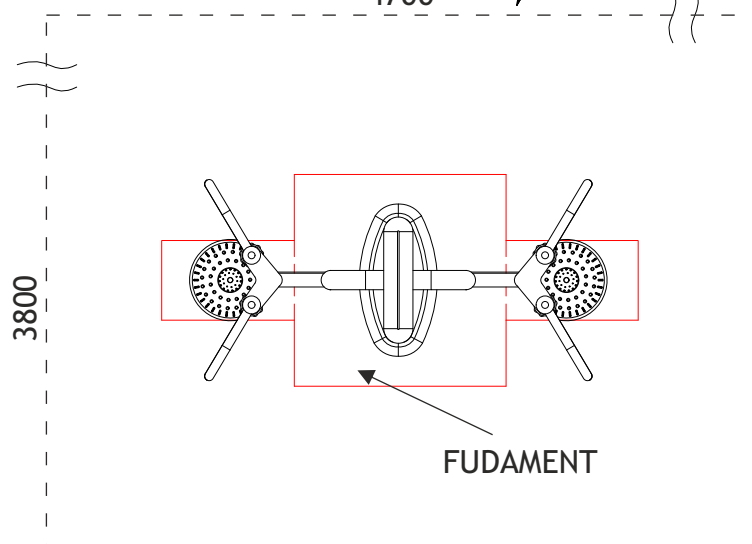

Masażer pleców i twister siedzący THJ-D20

**SKALA
1:30**

PN-EN 1176-1:2009, PN-EN 1176-7:2009
PN-EN ISO 20957-1:2014-02.

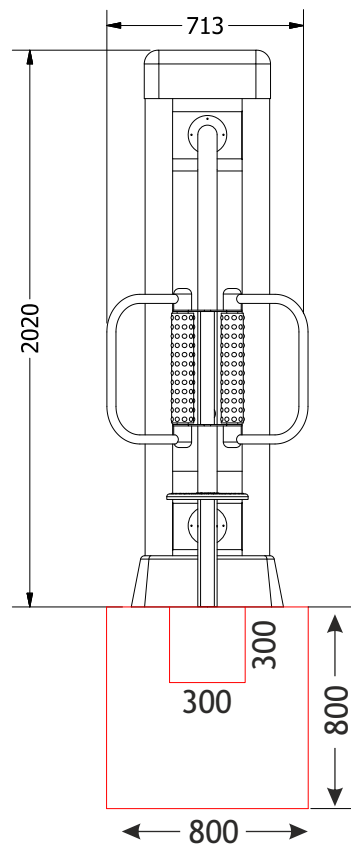
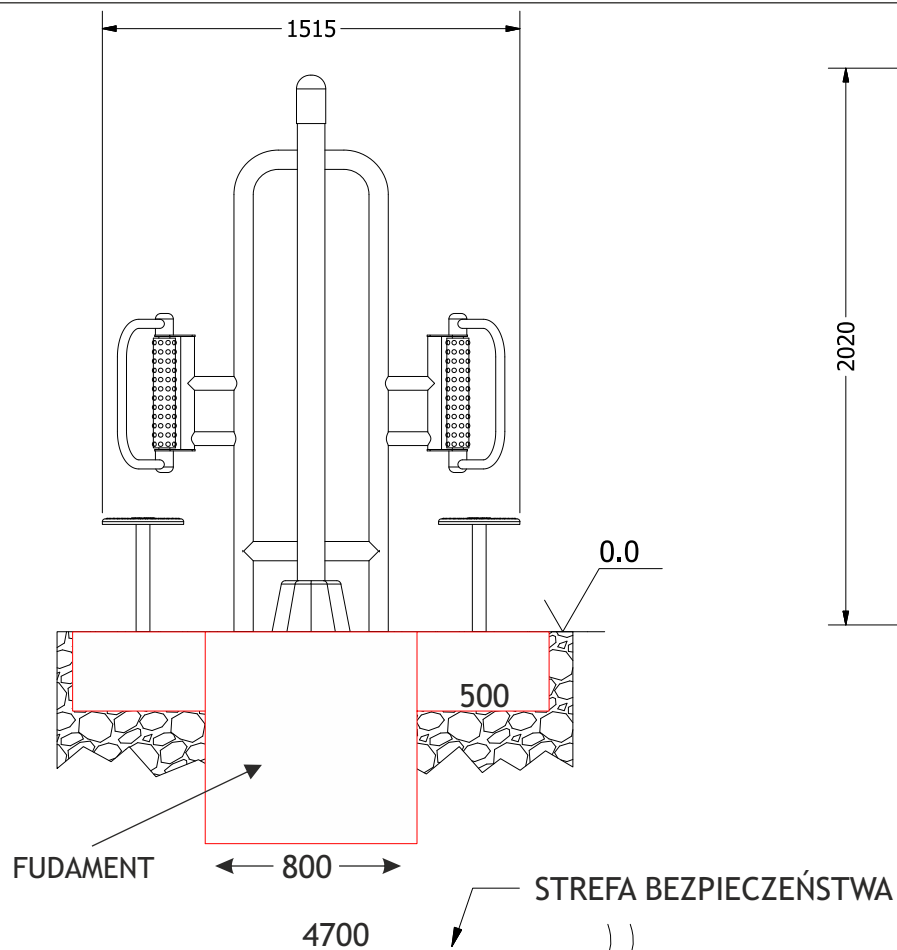

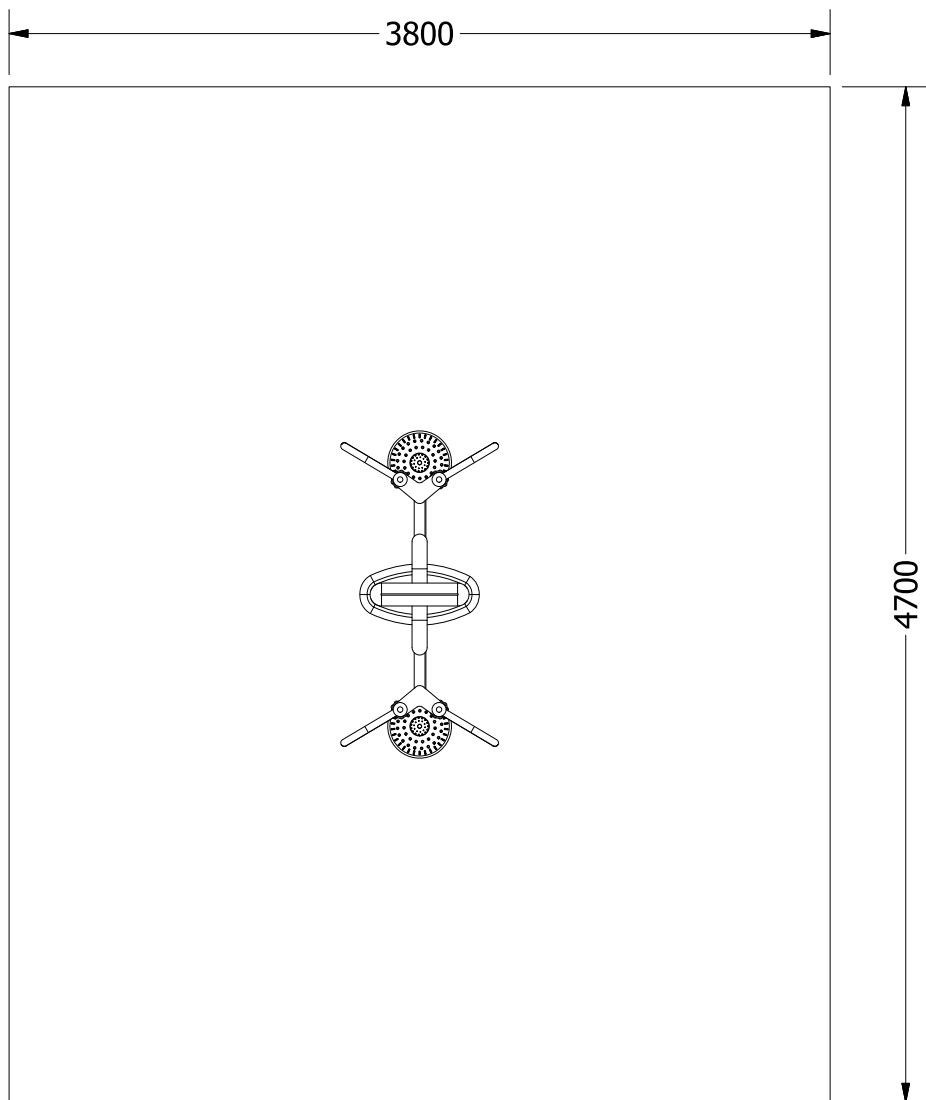

| | |
|----------------------|---|
| Max. waga ćwiczącego | 120 kg |
| Funkcje | Pomaga usunąć napięcie mięśni, stymuluje krążenie. |
| Stopień trudności | Łatwy |
| Certyfikaty | Urządzenie posiada certyfikat zgodności z polskimi normami: PN-EN 1176-1:2009, PN-EN 1176-7:2009, PN-EN ISO 20957-1:2014-02 |

Zaangażowane partie mięśni

